

CRANKSHAFT AND FRONT BEARING COVER

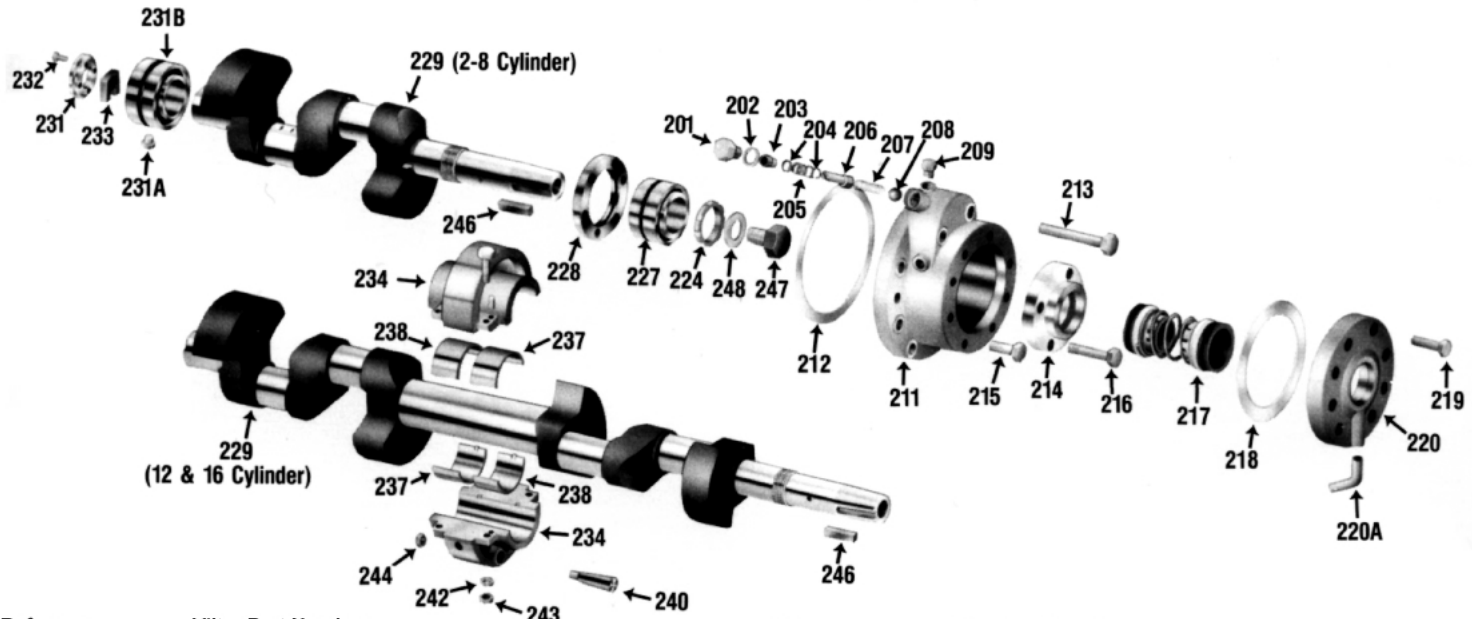

Reference Number	440	Vilter Part Number 450	450XL	Description
201	30651B	30651B	30651B	Cap, Valve
201-208	KT486	KT486	KT486	Oil Relief Valve Kit
209	13264B	13264B	13264B	Plug, 1/4" Pipe
209-211	A36240A	A36240A	-	Cover, Front Bearing Assy. For 2-1/2" Shaft (Requires Oil Orifice in Item #214)
209-211	A36241A	A36241A	A36241A	Cover, Front Bearing Assy. For 3" Shaft (Requires Oil Orifice in Item #214)
212	31890A	31890A	31890A	Gasket, Bearing Cover
213	13159E	13159E	13159E	Screw, 5/8" X 4" Socket Hd.
214	31885A	31885A	-	Retainer, Front Bearing (w/oil hole) for 2-1/2" Shaft
214	33500A	33500A	33500A	Retainer, Front Bearing (w/oil hole) for 3" Shaft
215	13152E	13152E	13152E	Screw, 5/8" X 2" Hex. Head
216	13153Q	13153Q	13153Q	Screw, 1/2" X 4" Hex. Head
217	A33483A	A33483A	-	Seal, 2-1/2" Shaft Assembly
217	A33489A	A33489A	A33489A	Seal, 3" Shaft Assembly
218	31897A	31897A	-	Gasket, 2-1/2" Shaft Seal Cover
218	33496A	33496A	33496A	Gasket, 3" Shaft Seal Cover
219	13153F	13153F	13153F	Screw, 1/2" X 1-3/4" Hex. Hd.
220	31044A	31044A	-	Cover, 2-1/2" Shaft Seal
220	32564A	32564A	32564A	Cover, 3" Shaft Seal
220A	35078A	35078A	35078A	Tube, Oil Drain
224	KT366	KT366	-	Locknut, 2-1/2" Shaft
224	KT367	KT367	KT367	Locknut, 3" Shaft

Reference Number	440	Vilter Part Number 450	450XL	Description
227	KT368	KT368	-	Front Bearing, 2-1/2" Shaft
227	KT369	KT369	KT369	Front Bearing, 3" Shaft
228	33144A	33144A	-	Ring, 2 1/2" Shaft, Front Bearing Retainer
228	33145A	33145A	333145A	Ring, 3" Shaft, Front Bearing Retainer
229	Not Sold Separately			Crankshaft, Bare Shaft
224-244	*			Crankshaft with Bearings
231	31904A	31904A	31904A	Retainer, Rear Bearing
231A/231B	KT353	KT353	KT353	Rear Bearing and Lock Pin
232	1736G	1736G	1736G	Screw, 5/16" X 1-1/2" Hex. Hd.
233	33403A	33403A	33403A	Crank, Oil Pump Drive
234	A32163A	A32163A	A32163A	Case, Bearing Support
237	33508A	33508A	33508A	Bearing Half, Upper Right or Lower Left
238	33508B	33508B	33508B	Bearing Half, Upper Left or Lower Right
240	33497A	33497A	33497A	Pin, Threaded Taper
242	13165F	13165F	13165F	Washer, 1/2" Lock
243	1726E	1726E	1726E	Nut, 1/2" Hex
244	13253F	13253F	13253F	Nut, 9/16" Hex.
246	31994B	31994B	-	Key, 2-1/2" Crankshaft
246	33505B	33505B	33505B	Key, 3" Crankshaft
247	31956A	31956A	31956A	Screw Flywheel Hub
248	33495A	33495A	33495A	Washer, 3" Shaft, Flywheel Hub Screw

* Check your Operator's Manual for correct Part Number for your specific compressor model. Splash shield included in crankshaft with bearings.